

# Solid State Relays Industrial, 1-Phase ZS w. LED Types RS 23, RS 40, RS 48



- Zero switching AC Solid State Relay
- Direct copper bonding (DCB) technology
- LED indication
- Clip-on IP 20 protection cover
- Self-lifting terminals
- Housing free of moulding mass
- 2 input ranges: 3-32 VDC and 18-36 VAC/VDC
- Operational ratings up to 40 AACrms and 480 VAC
- Non-repetitive voltage: Up to 1200 V<sub>p</sub>
- Opto-insulation: > 4000 VACrms

## Product Description

The zero switching relay with triac (10 A) or alternistor output (25 A, 40 A) is an inexpensive solution for resistive loads. The zero switching relay switches ON when the sinusoidal voltage crosses zero and switches OFF when

the current crosses zero. The LED indicates the status of the control input. The clip-on cover is securing touch protection to IP 20. Output terminals can handle cables up to 16 mm<sup>2</sup>.

## Ordering Key

**RS 1 A 23 D 25**

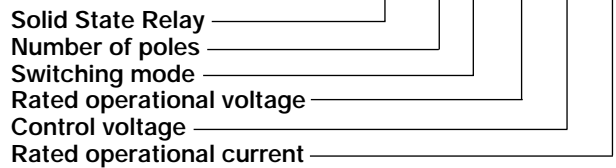

## Type Selection

Switching mode	Rated operational voltage	Rated operational current	Control voltage
A: Zero Switching	23: 230 VACrms 40: 400 VACrms 48: 480 VACrms	10: 10 AACrms 25: 25 AACrms 40: 40 AACrms	LA: 18 to 36 VAC/VDC D: 3 to 32 VDC* <small>*4 to 32 VDC for 480VAC types</small>

## Selection Guide

Rated operational voltage	Non-rep. voltage	Control voltage	Rated operational current		
			10 A	25 A	40 A
230 VACrms	650 V <sub>p</sub>	3-32 VDC	RS1A23D10	RS1A23D25	RS1A23D40
		18-36 VAC/DC	RS1A23LA10	RS1A23LA25	RS1A23LA40
400 VACrms	850 V <sub>p</sub>	3-32 VDC	RS1A40D10	RS1A40D25	RS1A40D40
		18-36 VAC/DC	RS1A40LA10	RS1A40LA25	RS1A40LA40
480 VACrms	1200 V <sub>p</sub>	4-32 VDC	RS1A48D10	RS1A48D25	RS1A48D40
		18-36 VAC/DC	RS1A48LA10	RS1A48LA25	RS1A48LA40

## General Specifications

	RS1A23...	RS1A40...	RS1A48...
Operational voltage range	42 to 265 VACrms	42 to 440 VACrms	42 to 530 VACrms
Non-rep. peak voltage	≥ 650 V <sub>p</sub>	≥ 850 V <sub>p</sub>	≥ 1200 V <sub>p</sub>
Zero voltage turn-on	≤ 15 V	≤ 15 V	≤ 15 V
Operational frequency range	45 to 65 Hz	45 to 65 Hz	45 to 65 Hz
Power factor	≥ 0.95 @ 230 VACrms	≥ 0.95 @ 400 VACrms	≥ 0.95 @ 480 VACrms
Approvals	UL, CSA	UL, CSA	UL, CSA
CE-marking <small>(external filter for EN 50081-1 needed)</small>	Yes	Yes	Yes

## Input Specifications

	RS1A..D..	RS1A..LA...
<b>Control voltage</b> RS1.23..,RS1.40. RS1.48..	3-32 VDC 4-32 VDC	18-36 VAC/DC
<b>Pick-up voltage</b> RS1.23..,RS1.40. RS1.48..	≤ 2.75 VDC ≤ 3.75 VDC	≤ 18 VAC/DC
<b>Reverse voltage</b>	≤ 32 VDC	-
<b>Drop out voltage</b>	≥ 2 VDC	≥ 5 VAC/DC
<b>Input current @ max input voltage</b>	≤ 12 mA	≤ 15 mA
<b>Response time pick-up</b>	≤ 1/2 cycle	≤ 1 cycle
<b>Response time drop-out</b>	≤ 1/2 cycle	≤ 2 cycles

## Output Specifications

	RS1A...10	RS1A...25	RS1A...40
<b>Rated operational current</b> AC51 @ Ta=25°C	10 Arms	25 Arms	40 Arms
<b>Min. operational current</b>	150 mA	150 mA	150 mA
<b>Rep. overload current t=1 s</b>	< 12 AACrms	< 37 AACrms	< 60 AACrms
<b>Non-rep. surge current t=10 ms</b>	100 Ap	230 Ap	300 Ap
<b>Off-state leakage current @ rated voltage and frequency</b>	< 3 mArms	< 3 mArms	< 3 mArms
<b>I<sup>2</sup>t for fusing t=1-10 ms</b>	≤ 50 A <sup>2</sup> s	≤ 310 A <sup>2</sup> s	≤ 450 A <sup>2</sup> s
<b>Critical di/dt</b>	≥ 10 A/μs	≥ 50 A/μs	≥ 100 A/μs
<b>On-state voltage drop @ rated current</b>	≤ 1.6 Vrms	≤ 1.6 Vrms	≤ 1.6 Vrms
<b>Critical dV/dt off-state</b>	≥ 250 V/μs	≥ 250 V/μs	≥ 250 V/μs

## Thermal Specifications

	RS1A...10	RS1A...25	RS1A...40
<b>Operating temperature</b>	-20° to 70°C	-20° to 70°C	-20° to 70°C
<b>Storage temperature</b>	-40° to 100°C	-40° to 100°C	-40° to 100°C
<b>Junction temperature</b>	≤ 125°C	≤ 125°C	≤ 125°C
<b>R<sub>th</sub> junction to case</b>	≤ 4.80 K/W	≤ 1.10 K/W	≤ 0.90 K/W
<b>R<sub>th</sub> junction to ambient</b>	≤ 40 K/W	≤ 20 K/W	≤ 20 K/W

## Housing Specifications

<b>Weight</b>	Approx. 60 g
<b>Housing material</b>	Noryl GFN 1, black
<b>Baseplate</b>	Aluminium
<b>Potting compound</b>	None
<b>Relay</b>	
Mounting screws	M5
Mounting torque	1.5-2.0 Nm
<b>Control terminal</b>	
Mounting screws	M3 x 9
Mounting torque	0.5 Nm
<b>Power terminal</b>	
Mounting screws	M5 x 9
Mounting torque	2.4 Nm

## Insulation

<b>Rated insulation voltage</b> Input to output	≥ 4000 VACrms
<b>Rated insulation voltage</b> Output to case	≥ 4000 VACrms



## Heatsink Dimensions (load current versus ambient temperature)

### RS10.

Load current [A]	Thermal resistance [K/W]						Power dissipation [W]
	20	30	40	50	60	70	
10.0	3.14	2.38	1.61	0.84	0.07	-	14
9.0	4.05	3.17	2.29	1.41	0.53	-	12
8.0	5.21	4.18	3.16	2.13	1.11	0.08	11
7.0	6.72	5.50	4.29	3.07	1.86	0.64	9
6.0	8.76	7.29	5.82	4.35	2.88	1.41	7
5.0	11.65	9.82	7.99	6.16	4.33	2.49	6
4.0	16.0	13.7	11.29	8.90	6.52	4.14	5
3.0	23.5	20.1	16.8	13.5	10.23	6.92	3
2.0	38.4	33.2	28.1	22.9	17.7	12.53	2
1.0	-	-	-	-	-	29.5	1

Ambient temp. [°C]

Junction to ambient thermal resistance, $R_{thj-a}$	< 40.0	K/W
Junction to BTB tab thermal resistance, $R_{thj-t}$	< 2.00	K/W
BTB tab to case thermal resistance, $R_{th t-s}$	< 2.80	K/W
Case to heatsink thermal resistance, $R_{th c-s}$	< 0.20	K/W
Maximum allowable BTB case temperature	100	deg.C
Maximum allowable junction temperature	125	deg.C

### RS25.

Load current [A]	Thermal resistance [K/W]						Power dissipation [W]
	20	30	40	50	60	70	
25.0	1.92	1.61	1.30	1.00	0.69	0.39	33
22.5	2.39	2.04	1.69	1.34	0.99	0.63	28
20.0	3.00	2.59	2.18	1.77	1.36	0.95	24
17.5	3.68	3.19	2.71	2.22	1.74	1.25	21
15.0	4.49	3.90	3.32	2.73	2.14	1.56	17
12.5	5.64	4.91	4.18	3.45	2.72	1.99	14
10.0	7.39	6.44	5.49	4.55	3.60	2.65	11
7.5	10.34	9.03	7.71	6.39	5.07	3.75	8
5.0	16.3	14.2	12.2	10.11	8.05	5.99	5
2.5	-	-	25.7	21.4	17.0	12.7	2

Ambient temp. [°C]

Junction to ambient thermal resistance, $R_{thj-a}$	< 20.0	K/W
Junction to case thermal resistance, $R_{thj-c}$	< 1.10	K/W
Case to heatsink thermal resistance, $R_{th c-s}$	< 0.20	K/W
Maximum allowable case temperature	100	deg.C
Maximum allowable junction temperature	125	deg.C

## Heatsink Dimensions (cont.)

### RS40..

Load current [A]	Thermal resistance [K/W]						Power dissipation [W]
	20	30	40	50	60	70	
40.0	1.10	0.89	0.68	0.47	0.26	0.05	48
36.0	1.41	1.18	0.94	0.70	0.46	0.22	42
32.0	1.81	1.54	1.26	0.98	0.70	0.43	36
28.0	2.33	2.01	1.68	1.35	1.03	0.70	31
24.0	2.95	2.56	2.16	1.77	1.38	0.98	25
20.0	3.71	3.22	2.73	2.24	1.75	1.27	20
16.0	4.85	4.22	3.59	2.96	2.33	1.69	16
12.0	6.78	5.91	5.03	4.16	3.29	2.41	11
8.0	10.65	9.30	7.94	6.58	5.23	3.87	7
4.0	22.3	19.5	16.7	13.9	11.1	8.25	4

Ambient temp. [°C]

Junction to ambient thermal resistance, $R_{thj-a}$	< 20.0	K/W
Junction to case thermal resistance, $R_{thj-c}$	< 0.90	K/W
Case to heatsink thermal resistance, $R_{th c-s}$	< 0.20	K/W
Maximum allowable case temperature	100	deg.C
Maximum allowable junction temperature	125	deg.C

## Heatsink Selection

Carlo Gavazzi Heatsink (see Accessories)	Thermal resistance...	...for power dissipation
No heatsink required	---	N/A
RHS 300	5.00 K/W	> 0 W
RHS 100	3.00 K/W	> 25 W
RHS 45A	2.70 K/W	> 60 W
RHS 45B	2.00 K/W	> 60 W
RHS 90	1.35 K/W	> 60 W
RHS 45A plus fan	1.25 K/W	> 0 W
RHS 45B plus fan	1.20 K/W	> 0 W
RHS 112	1.10 K/W	> 100 W
RHS 301	0.80 K/W	> 70 W
RHS 90 plus fan	0.45 K/W	> 0 W
RHS 112 plus fan	0.40 K/W	> 0 W
RHS 301 plus fan	0.25 K/W	> 0 W
Consult your distribution	> 0.25 K/W	N/A
Infinite heatsink - No solution	---	N/A



## Dimensions

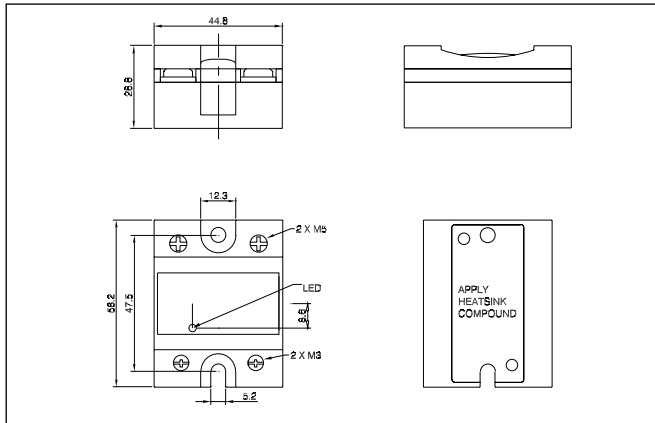

## Functional Diagram

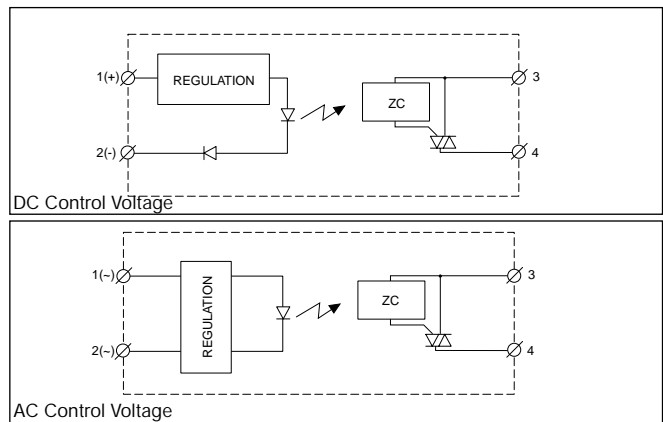

## Fast-on terminals



- Fast-on tabs
- Type R..F.
- Screw mounted fast-on terminals
- Flat (0°) and angled (45°) orientation
- Input tab width: 4.8mm
- Output tab with: 6.3mm
- Tab dimensions according to DIN 46342 part 1
- Pure tin-plated brass

## Ordering Key

**RS1A48D40 F 4\***

RS, RM Solid State Relay  
Fast-on terminals  
Tab orientation

\* 0: Flat (0°)  
4: Angled (45°)

## Other Accessories

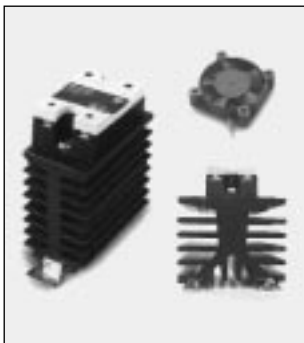

- Heatsinks and fans
- Type RHS...
- 0.25 to 5.00 k/W
- Single and dual relay types



- Touch safety cover
- Type RMIP20
- IP20 protection degree
- Pack size: 20 pieces

All accessories can be ordered pre-assembled with Solid State Relays.  
Other accessories include DIN rail adaptors, fuses, varistors and spacers.  
For further information refer to Accessories datasheets.